

MB-23

Machine-room above electrical gearless solutions

Compact machine-room solutions mainly designed for existing buildings.

Latest direct drive technology.

The affordable and functional option when a lift with machine room is replaced.

GENERAL SPECIFICATIONS

Load	225 to 630 kg
Capacity	3 to 8 persons
Speed	1 m/s
Maximum travel	60 m
Maximum floors served	21 floors
Entrances	1 front - 2 open through
Drive system	Direct gearless
Controller	ARCA II controller, low energy microprocessor
Door types	Semiautomatic + Articulated (BUS) - Automatic side-opening - Automatic central-opening
Clear door opening	From 500 to 900 mm
Door height	2,000 - 2,100 - 2,200 - 2,300 mm
Car dimensions	Parametric car dimensions
Internal car height	2,100 - 2,200 - 2,300 - 2,400 mm
Aesthetic solutions	MBR1 - MBR2 - MBR3 - MBR4 - MBS1 - MBS2 - MBS3 - MB Plus

Standard **Optional**

1 Machine room

A traditional solution simplifying lift maintenance.



2 Drive

Compact, quiet, gearless, energy efficient, speed regulated (VVVF) permanent magnet electric motor.



3 Accessible space below the pit

Adapts the lift to suit buildings which have an accessible space below the pit (optional).



4 Traction ropes

Orona small diameter ropes replace traditional steel ropes. As a result of their lighter weight, longer lifespan and greater flexibility, it is possible to use a more compact, efficient and eco-friendly gearless machine.



5 Doors

Compact permanent magnet motor for quick, accurate and quiet door operation giving the most advanced performance. Advanced door opening and full height infra red door protection edges. Optional Solid Door for high flow situations.



6 Parametric / Flexible

Flexible car and door configurations ensure available shaft dimensions can be optimised (optional).



7 Automatic rescue system

With floor level indication to ensure fast, efficient and safe evacuation of passengers in the event of an emergency. As an option, the system can incorporate a fully-automatic rescue device to evacuate passengers in the event of a power failure.



STANDARD DIMENSIONS

Load / Capacity	Car				Lift shaft *										
					Entrances		Side-opening doors		Central-opening doors HH		HF Pit		HUP ⁴ Last Floor		
	Persons	Q Load	AC Width	FC Depth	PL Clear opening	Accessibility	No. of entrances	AH ¹ Width	FH ² Depth	AH ¹ Width	FH ³ Depth	Std.	With safety cube	Without safety cube (EN 81-21)	Std.
4	320 kg	825	1,100	700		1	1,300	1,400	1,250	1,400	1,000	705	285	3,380	2,910
						2 x 180 ⁰		1,550		1,550					
6	450 kg	1,000	1,250	800	♿	1	1,450	1,550	1,450	1,550					
						2 x 180 ⁰		1,700		1,700					
8	630 kg	1,100	1,400	900	♿	1	1,600	1,700	1,550	1,700					
						2 x 180 ⁰		1,850		1,850					
		1,200	1,250	900	♿	1	1,650	1,550	1,650	1,550					
						2x 180 ⁰		1,650		1,700					

1. Accessible space below the pit (counterweight with safety gear) add 50 mm to AH.
2. Shaft depth with door tracks projecting 60 mm on the landing.
3. Shaft depth with door tracks projecting 40 mm on the landing.

4. HUP minimum for internal car height (HC) 2,100 mm (HUP = HC + 1,280).
- HH - Four panel central door
- * Minimum plumb measurements.

LAYOUT

1 Entrance

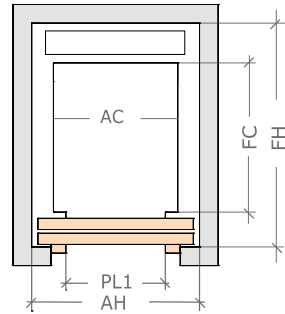

Wide-framed door detail

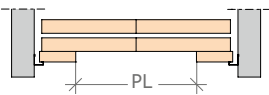

2 Entrances (open through)

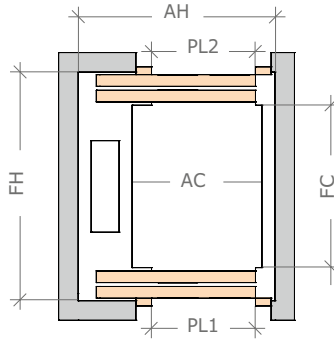

Wide-framed door detail

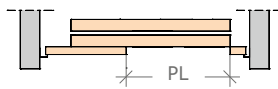

Vertical section

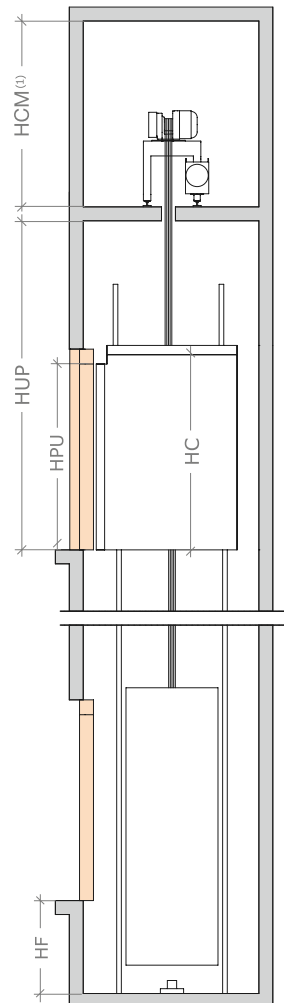

CUSTOMISED CAR DIMENSIONS

									8	8	6	5	1,800											
								8	8	7	6	5	1,700											
									8	7	5	5	1,600											
									8	7	6	5	4	1,500										
									8	7	6	5	4	1,400										
									8	8	7	6	5	4	4	1,300								
									8	8	7	6	5	5	4	4	1,200							
									8	8	7	6	5	5	4	4	3	1,100						
									8	7	7	6	5	5	4	4	4	3	1,000					
									8	8	7	6	6	5	5	4	4	4	3	900				
									8	7	7	6	5	5	5	4	4	4	3	800				
									7	6	6	5	5	4	4	4	4	3		700				
									5	5	5	4	4	4	4	3	3			600				
1,800	1,700	1,600	1,500	1,400	1,300	1,200	1,100	1,000	900	800	700	600	AC	500	600	700	800	900	1,000	1,100	1,200	1,300	1,400	PL

Note: Car width and depth variable in increments of 5 mm.. For simplification, table samples show increments of 100 mm.

[1] HCM - minimum 2,000 mm